

FIELD INSPECTION PROCEDURE

BREAK-SAFE® Load Break & Pick-up Tool

Follow the steps below before EACH use of the BREAK-SAFE®. This procedure does NOT replace or eliminate the periodic maintenance that is recommended every 2 years.

PATENT NO. 6,078,008 Other Patents Pending

1. VISUAL INSPECTION

Visually inspect the tool. If any of the following are found, remove the tool from the field and perform service:

- Soot or Dirt buildup on components
- Damage to contacts
- Cracks of 1/4" or more on outer tube
- Damaged Load Break Ring. Ring should rotate freely (shaft should NOT rotate)
- Damaged or discolored Yellow Tube
- Damaged Conductor Hook or Duckbill
- Loose Conductor Bar
- Damaged Safety Lock
- Out of Date Maintenance Decal (maintenance recommended every 2 years)

2. CONTINUITY

The Brass Contacts do not carry the load during Load Break operation. The current path will exist inside the tool until the load break mechanism is triggered.

A) With the tool in the CLOSED position, use a voltmeter, confirm continuity exists between the Conductor Bar and the Conductor Hook.

B) Confirm continuity exists while pulling the Load Break Ring toward the open position. Continuity should exist until the load break mechanism is engaged and the tool locks in the open position.

C) Confirm NO continuity exists between the Conductor Bar and the Conductor Hook when the tool is in the fully opened positioned.

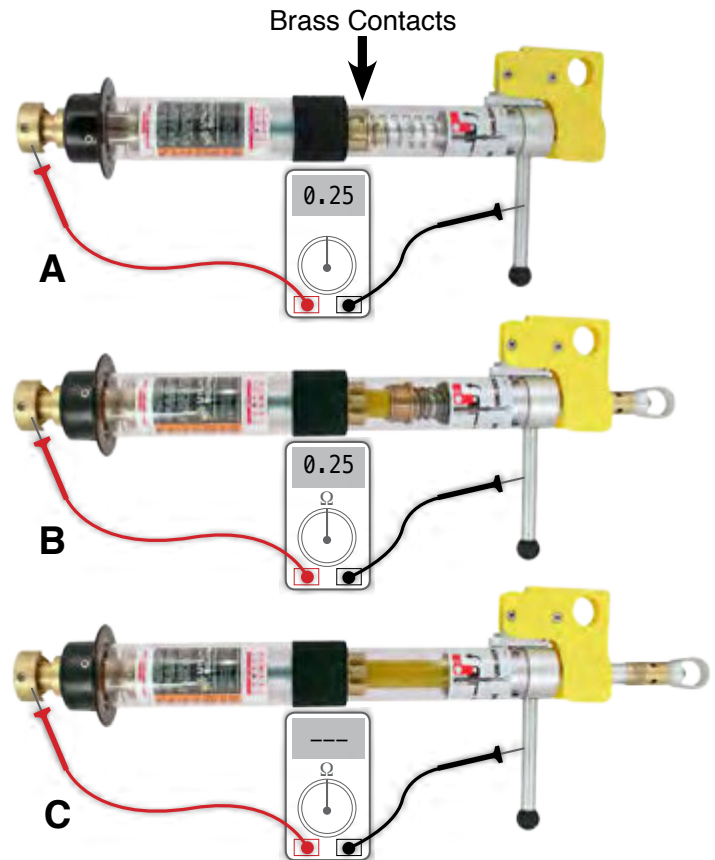

3. RESET TOOL

The BREAK-SAFE® will only reset when the Brass Contacts are fully seated.

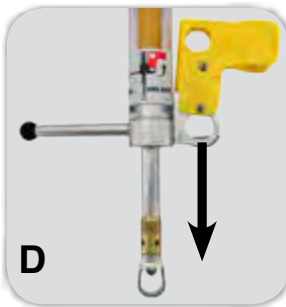

Exert a steady downward movement on the Load Pick-up Trigger (D). The Load Break Ring Assembly should retract forcefully into the Clear Tube Assembly. The tool should operate firmly and smoothly.

With the tool in the Lock Close position, confirm the Brass Contacts are fully seated (E). The Brass Contacts will fit inside one another so the fingers of the top Brass Contact are touching the lip of the lower Brass Contact.

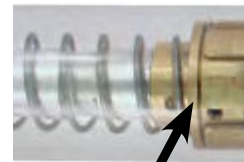

E Fully Seated



F

The Brass Contacts should remain seated with the tool in the CLOSED position (F). Push the Load Break Ring up and into the tool to ensure the Brass Contacts are fully seated. The tool will require service and should NOT be used if the Brass Contacts cannot be fully seated.



WARNING



Carefully read and fully understand the manual prior to operating, maintaining or testing this device. Improper operation, handling or maintenance of this device can result in death, grievous personal injury and or equipment damage.

Phone (828)323-8914
 Fax (828)323-8410
 Email sales@utilityolutionsinc.com
 Web www.utilityolutionsinc.com
 101 33rd Street Drive SE · Hickory, NC 28602

B-01032
 USBS Field Inspection (12-17-18)
 Copyright © 2018 Utility Solutions, Inc.

UTILITY SOLUTIONS
Lineman driven. Field proven.®

FIELD INSPECTION PROCEDURE BREAK-SAFE® Load Break & Pick-up Tool

Floating Head

Duckbill Head

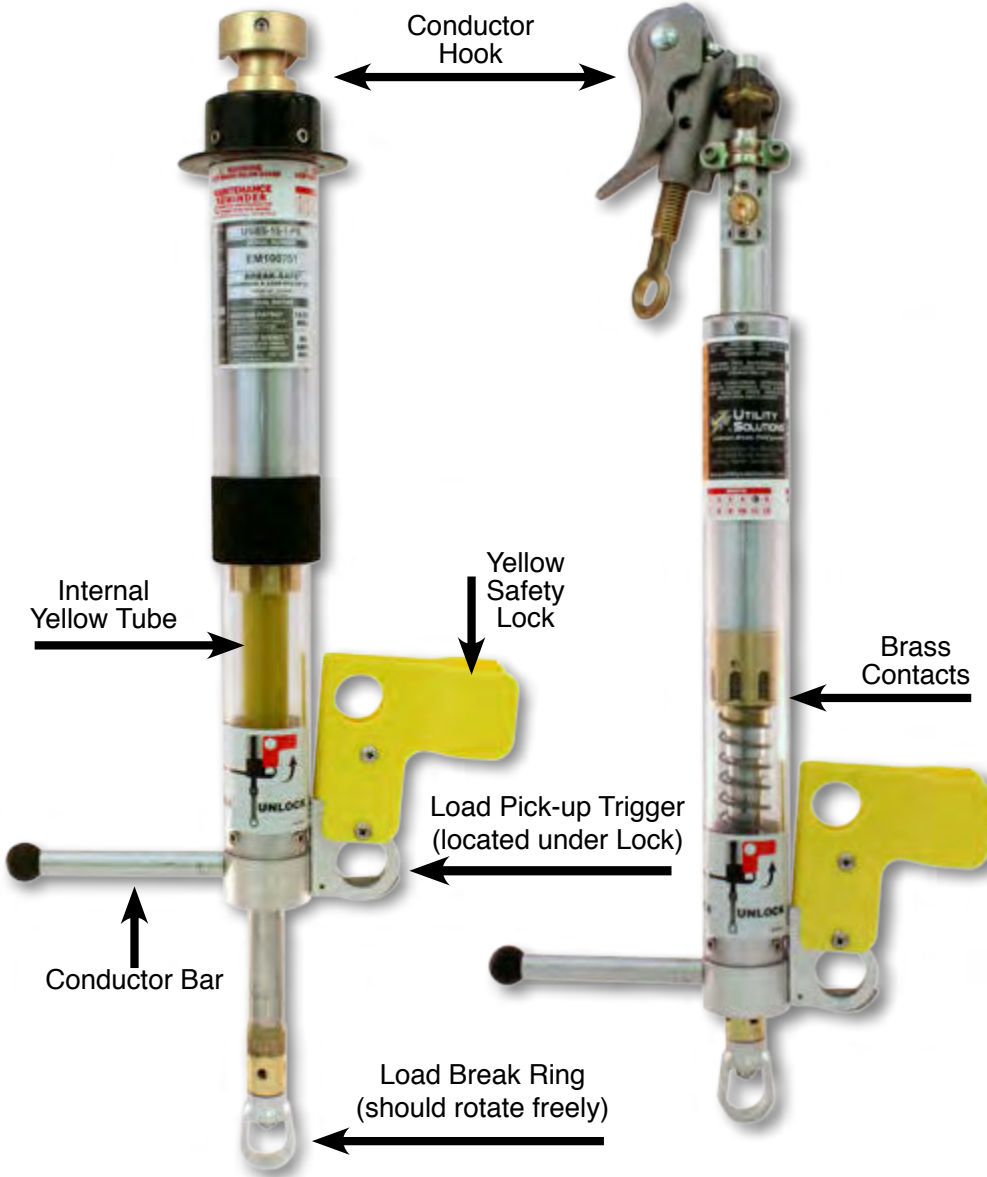

**LOCK
CLOSE**



**LOCK
OPEN**

LOCKED

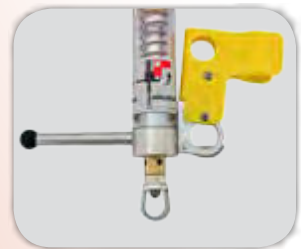

CLOSE



OPEN

UNLOCKED



WARNING



Always remove the BREAK-SAFE® from the circuit, or remove the jumper attached to the conductor bar, after each load break operation.
The BREAK-SAFE® is not rated insulation nor is it considered a "visible gap".



DANGER



The Safety Lock does not RESET the tool. Refer to Inspection Procedure on reverse side and the Operation Manual for complete instructions on properly resetting the BREAK-SAFE™.

Phone (828)323-8914
 Fax (828)323-8410
 Email sales@utilityolutionsinc.com
 Web www.utilityolutionsinc.com
 101 33rd Street Drive SE · Hickory, NC 28602

B-01032
 USBS Field Inspection (12-17-18)
 Copyright © 2018 Utility Solutions, Inc.

 **UTILITY
SOLUTIONS**
Lineman driven. Field proven.®